

Description of Wireless Intelligent Network Services with Use Case Maps

Daniel Amyot and Rossana Andrade¹

*TSERG, School of Information Technology and Engineering, University of Ottawa
150 Louis Pasteur, Ottawa, Ontario, K1N 6N5, Canada
E-mail: {damyot | randrade}@site.uottawa.ca*

Abstract. Increasing complexity in telecommunications services requires ever more complex standards, and therefore the need for better means to write them. Over the years, scenario-driven approaches have been introduced in order to describe functional aspects of systems at several levels of abstraction. Their application to early stages of design and standardization processes raises new hopes in editing concise, descriptive, maintainable, and consistent documents that need to be understood by a variety of readers. In this context, this paper investigates a recent visual notation for causal scenarios called Use Case Maps. The goal is to better describe distributed systems and telecommunication standards, and to fill the gap between the stage where services are described informally and the stage where message sequence information is generated. As an example, this paper focuses on the Incoming Call Screening service of the new Wireless Intelligent Network standard.

Keywords. Causal Scenarios, Message Sequence Charts, Telecommunication Standards, Use Case Maps, Wireless Intelligent Network.

1. INTRODUCTION

Emerging telecommunications services require industries and standardization bodies (ANSI, ETSI, ISO, ITU, TIA, etc.) to describe increasingly complex functionalities, architectures, and protocols. This is especially true of wireless systems, where the mobility of users and of terminals brings an additional dimension of complexity. In that context, special attention has to be brought to the early stages of the design and standardization processes, where the focus should be on system and functional views rather than on details belonging to a lower level of abstraction, or to later stages in those processes.

Nowadays, communication services and features are commonly described using an amalgam of informal operational and declarative descriptions, tables, and visual notations such as *Message Sequence Charts* (MSCs) [15]. As these descriptions evolve, they quickly become error-prone and difficult to manage. There is an urgent need for high-quality documents that are concise, descriptive, maintainable, consistent, and understandable by readers with different needs and perspectives (designers, engineers, testers, marketing people, etc.). Over the years, several approaches have attempted to provide such documents. Proponents of formal methods have claimed to solve the problem by providing unambiguous and mathematical notations and verification techniques, but the penetration of these methods in industry and in standardization bodies remains, unfortunately, low [3]. Scenario-driven approaches have raised a higher level of interest and acceptance, mostly because of their intuitive representation of services [3][16]. This paper presents such a methodology, but with an approach to the level of scenario abstraction slightly different from that of most popular techniques. It focuses on the very first stage of design and standardization processes, where many information and design decisions are often lost or hidden behind implementation details. Such details should be omitted at this stage, whereas the general flow of responsibilities should be emphasized.

¹ Professor at the Computer Science Department, Federal University of Ceará, Brazil, and sponsored by CAPES (Brazilian Federal Agency of Graduate Studies).

Standardizing telecommunication systems and services results from a design process frequently comprised of three major stages (Figure 1). Services are first described from the user's point of view in prose form and with tables (stage 1), then with sequences of messages between the different functional entities involved (stage 2), and finally with (informal) specifications of protocols and procedures (stage 3). This three-stage methodology was first developed by ITU-T to describe services and protocols for ISDN [11].

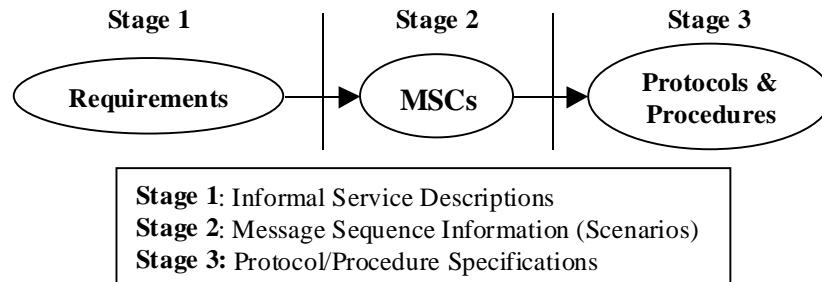

Figure 1 Three-Stage Methodology

Different architectural reference models, such as Open Distributed Processing (ODP) [13] and Intelligent Networks (IN) [14] are sometimes used to promote more uniform descriptions of these stages and to bridge the gap between the stages. In particular, the IN conceptual model contains four *planes*, each of which focuses on a different system viewpoint or levels of abstraction, hence encouraging an early separation of concerns. These are, from the more abstract to the more concrete: service plane, global functional plane, distributed functional plane, and physical plane.

The three stages of Figure 1 correspond respectively to IN's service, distributed functional, and physical planes, at least in theory if not in practice. Stage 1 documents contain informal descriptions of service operations, such as normal procedures with successful outcome, exception procedures or unsuccessful outcome, and interactions with other services. The Distributed Functional Model (DFM), related to the distributed functional plane, is illustrated in stage 2. The third stage (and often the second one too) presents services with the help of a Network Reference Model (NRM) which corresponds to the physical plane. IN's global functional plane does not have a clear counterpart in this methodology.

The goal of this article is two-fold. Firstly, it introduces a visual notation for causal scenarios called *Use Case Maps* (UCMs) [7][9][19]. This notation represents a new means to improve the three-stage methodology by providing better stage 1 documents while at the same time paving the way towards stage 2 descriptions. Secondly, this paper presents an application of UCMs to a new standard, namely the *Wireless Intelligent Network* (WIN) [17]. In particular, it focuses on one complex feature, the *Incoming Call Screening* (ICS) service, from the WIN Phase 1 specification approved by committee TIA TR45.2 in December 1998. ICS regroups, under the umbrella of one single service, several conventional features for filtering and forwarding calls according to user policies, but in the context of mobile telephony.

This article is structured as follows. The basic concepts of UCMs and their use in a three-stage methodology are presented in Section 2. Section 3 introduces WIN, and more particularly its Distributed Functional Model, Network Reference Model, and mapping of functional entities to network entities. ICS is also discussed in that section. Next, Section 4 illustrates how the UCMs for ICS were constructed. Finally, Section 5 discusses important results and future work. Readers unfamiliar with wireless telephony can also refer to the acronym table that follows the references.

2. USE CASE MAPS

The visual notation *Use Case Maps* aims to capture operational requirements of communicating and distributed systems. UCMs represent scenarios as causal paths cutting across organizational structures of components. In stage 1, requirements usually suffer from heavy instabilities, whereas scenarios and potential component topologies (structures of functional and network entities) are volatile. UCMs fit well in approaches that intend to bridge the gap between requirements and an abstract system design (stage 2), where a tentative distribution of system behaviors over a structure is being introduced.

UCMs use behavior as a concrete, first-class architectural concept. They describe scenarios in terms of *causal relationships* between *responsibilities*. UCMs usually emphasize the most relevant, interesting, and critical functionalities of the system. With the UCM notation, scenarios are expressed above the level of messages exchanged between components, hence they are not necessarily bound to a specific underlying structure. UCMs provide a path-centric view of system functionalities and improve the level of reusability of scenarios. To illustrate these concepts and part of the notation, this section includes examples referring to a much simplified version of WIN's ICS service. For a detailed description of the UCM notation, the reader should refer to [7], [9] and [19].

2.1. Overview of the Notation with a Simple Example

Figure 2 shows a UCM where an incoming call is tentatively initiated (IncomingCall). This causes a screening function to be executed according to the subscriber's policies. In this scenario, two alternative results are considered. If the call initiator is on the receiver's screening list, then an announcement is played (PlayBlockAnnounce) and the call is blocked (CalledBlocked). Otherwise, there is no special treatment (NormalAlerting) and the call is accepted (CallSetup). In order for the figures and text to be more concise, the rest of the section uses abbreviations for the names specified in the UCM.

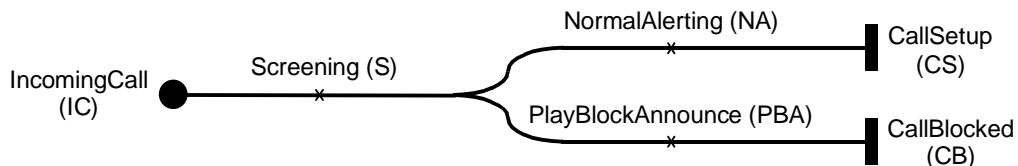

Figure 2 Use Case Map for a Simplified ICS Service

A UCM scenario starts with a triggering event or a pre-condition (filled circle labeled IC) and ends with one or more resulting events or post-conditions (bars), in our case CS or CB. A *route* is a path that links an initial cause to a final effect. Intermediate *responsibilities* (S, NA, and PBA) are activated along the way to form routes such as <IC, S, NA, CS>. Think of responsibilities as tasks to be performed, or as events to occur. The notation allows for alternative paths (the *OR-Fork* in the figure), concurrent paths, exception paths, timers, stubs/plugins, and synchronous or asynchronous interactions between paths.

Such UCMs have proved to be very useful in stage 1 descriptions of service functionalities. Their principal emphasis is on causality and responsibilities, without any reference to structures of components. Yet, they represent useful and powerful tools for the support of the thinking process and the evaluation of functional alternatives. This causal dependence between responsibilities should be documented as early as possible in the design process, before this information gets lost among the details of the behavior of individual components. This is especially true of concurrent, communicating, and distributed systems.

2.2. Evaluation of Structures

The notation supports the reuse of scenarios when the underlying structure is modified or refined. For instance, Figure 3(a) and Figure 3(b) illustrate two structures of *functional entities* (FEs), which are the components of IN's distributed functional plane. The example scenario (Figure 2) is bound differently to each collection of FEs. The same scenario can also be bound to the same structure, but in a different way, as shown in Figure 3(c). In stage 2 descriptions, different potential structures could undergo some evaluation (a.k.a. architectural reasoning). Scenarios described in terms of wired components, such as Message Sequence Charts or as interaction diagrams in the Unified Modelling Language (UML), would need to be rebuilt as soon as there is a change in the underlying structure, because the functionalities are tightly bound to how the structure looks like. UCMs require simpler modifications, consisting only of a new binding between the responsibilities and the components.

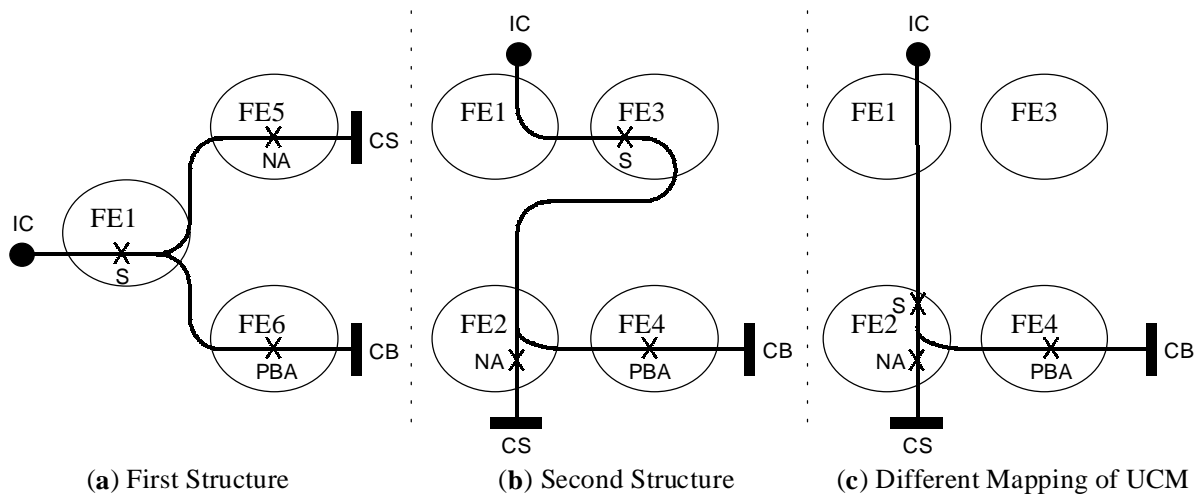

Figure 3 A Causal Scenario Bound to Different Structures

Going from stage 2 to stage 3 requires for the functional entities to be bound to *network entities* (NEs), the components of IN's physical plane. Again, different allocations are possible, and design decisions have to be made and documented. Two collections of NEs lead to different mappings in Figure 4(a) and Figure 4(b). In Figure 4(c), the structure remains the same as in Figure 4(b), but FE2 and FE3 are allocated differently.

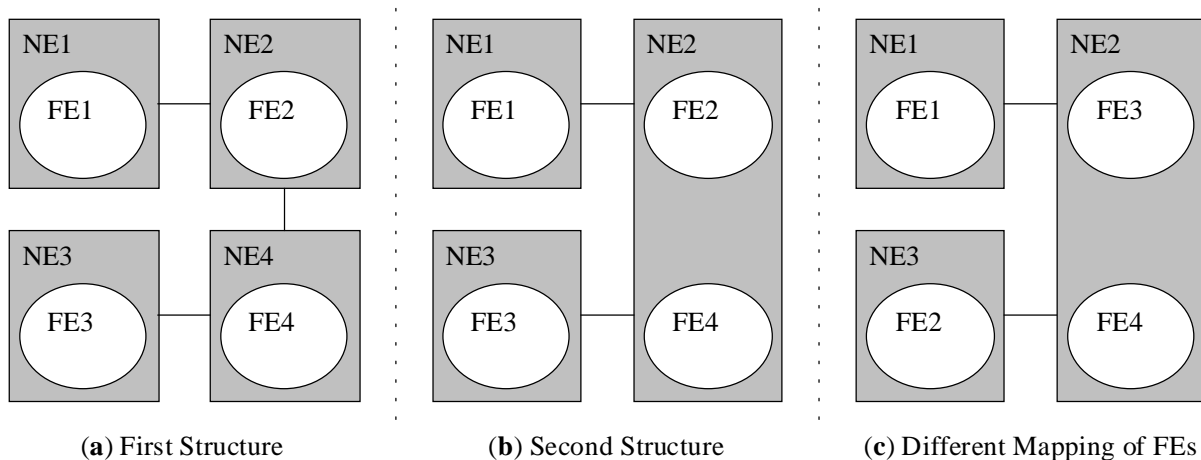

Figure 4 Different Bindings of Functional Entities to Network Entities

2.3. Refinement with Message Exchanges

A causal relationship can be refined in many ways in terms of message exchanges, depending on the component structure, on the availability of communication channels, and on the chosen protocols. In this paper, message exchanges are described by means of MSCs, a standardized notation where vertical lines represent communicating parties, horizontal arrows represent messages, boxes represent activities, and time increases from top to bottom [15].

Many MSCs could be valid according to a UCM, as long as the intended causal relationships between the responsibilities are satisfied. For instance, two communication channels (lines) link the components of Figure 5(a). They constrain the sequences of messages allowed for the implementation of causal relations in scenarios. This figure combines the allocation of responsibilities to FEs from Figure 3(c) and the allocation of FEs to NEs from Figure 4(c).

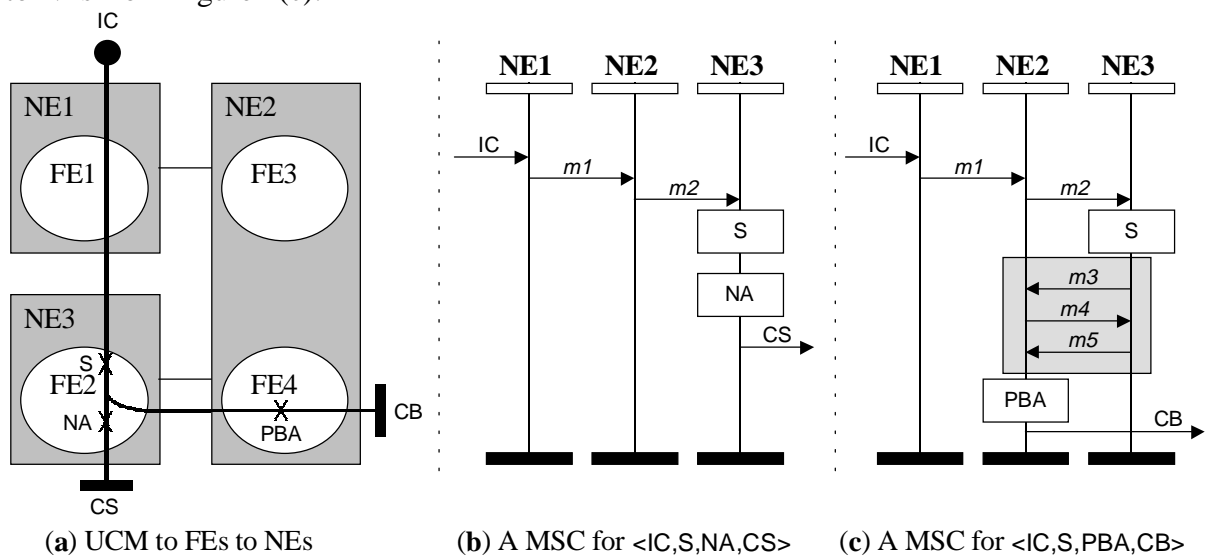

Figure 5 Generation of MSCs from UCM Routes Bound to a Structure

Figure 5(b) presents a MSC for the route $\langle IC, S, NA, CS \rangle$ where the exchange of messages is minimal. Notice that NE1 is not allowed to send messages directly to NE3, but messages can be forwarded through NE2. Figure 5(c) illustrates a possible MSC for the route $\langle IC, S, PBA, CB \rangle$, only this time more complex protocols are used between NE3 and NE2. The shaded area illustrates that multiple message exchanges (perhaps some sort of negotiation protocol) are used for the implementation of the causal relationship between S and PBA.

The number of routes in a UCM affects the number of resulting MSCs, and many alternative MSCs can result from a single route depending on the protocols and message exchanges selected by the designer. This type of decision is only relevant in the third stage of the methodology discussed in the introduction. Yet, many standards include MSCs based on network entities in stage 2, and sometimes even in preliminary stage 1 documents, hence skipping many decision steps. This hurts the design process by not separating concerns, by narrowing the number of potential implementations too soon, and by not documenting any of the information and design decisions illustrated by Figure 2 to Figure 5. As a result, a manufacturer who wants to build a product where the FEs are bound differently to the NEs needs to reverse-engineer many of these decisions, hence slowing and weakening the whole implementation process.

3. WIRELESS INTELLIGENT NETWORK

Wireless Intelligent Network (WIN) has been developed by the Telecommunication Industry Association (TIA) Standards Committee TR45.2 [18] to drive Intelligent Network capability into ANSI-41-based wireless networks [6]. The three major IN principles are service independence, separation of basic switching functions from service and application functions, and independence of applications from lower-level communication details. In order to support wireless networks, mobility functions have to be added to these IN principles.

WIN separates call processing intelligence and feature functionality from network switches, includes mobility management functions, and offers a diversity of enhanced services to subscribers. The first phase of the WIN standard covers three major services. First, *Calling Name Presentation* (CNAP) provides the name identification of the calling party (personal name, company name, “restricted”, “not available”) to the called party. Second, *Incoming Call Screening* (ICS) provides for alternate routing, blocking, or allowing of specified incoming calls. Third, *Voice Controlled Services* (VCS) employ voice recognition technology to allow wireless users to control features and services using spoken commands.

The WIN standard is based on the three-stage methodology illustrated in Figure 1, although the documentation sometimes deviates from the theoretical content addressed by these stages. Since the original ANSI-41-D wireless standard [6] was not based on IN principles and was focusing mainly on what would be the description of service and physical planes, a new chapter (number 7) had to be added to describe WIN’s distributed functional plane on the basis of IN’s Capability Set 2 (CS-2).

This section introduces WIN’s ICS service, as well as the Distributed Functional Model (DFM), Network Reference Model (NRM), and mapping of FEs to NEs described in the new chapter 7. For illustration purpose, the functional and network entities involved in the support of the ICS service have been shaded in gray in the next figures (these do not include entities related to mobile stations and base stations, which are used by most wireless services but are not specific to ICS).

3.1. Incoming Call Screening Service

Incoming Call Screening (ICS) is one of the enhanced services introduced in the first phase of the WIN standard. The incoming calls have one of the five potential termination treatments that correspond to the following screening functions: terminated normally to the subscriber (with normal alerting or with distinctive alerting), forwarded to another number, forwarded to voice mail, routed to subscriber-specific announcement, and blocked.

Beside these screening functions, ICS can use a number of screening factors to determine which termination action is appropriate. These factors are related to calling party characteristics like identity, speech or voice-based identification procedure, and passwords. They can also be related to called party characteristics such as location, status, date and time.

3.2. Distributed Functional Model

Figure 6 depicts the Distributed Functional Model with computational objects, called functional entities (FEs), and their relationships in the context of the WIN standard. A grouping of actions across one or more FEs, when coordinated by communication flows, provides the required WIN service execution. This functional model is non-service specific and does not imply any limitations regarding physical implementations or distribution of functions to physical platforms. It represents essentially the viewpoint of a network designer.

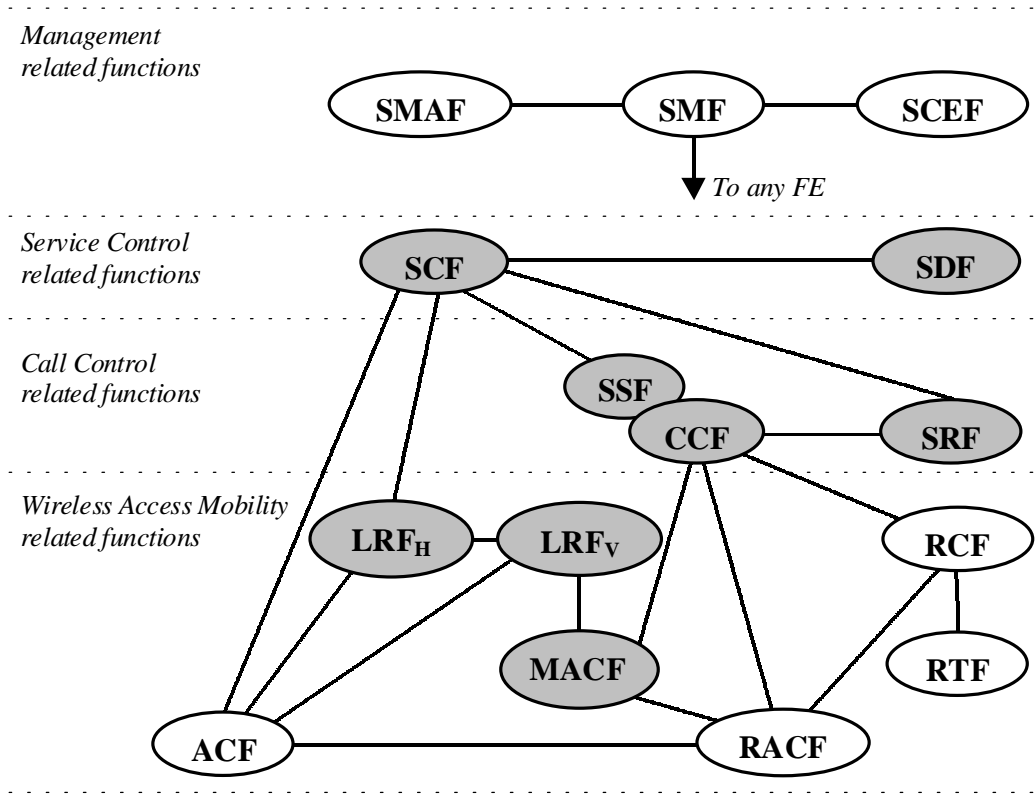

Figure 6 Wireless Distributed Functional Model
(adapted from Figure 1 of IS-41.7-WIN [18])

In this figure, it is assumed that some functional entities have links to other entities of their own type (it is the case for SCF, CCF, ACF, and RACF). The roles of the FEs are summarized below.

- *Authentication Control Function (ACF)*: provides the service logic and service data function for authentication, voice privacy and signaling message encryption.
- *Call Control Function (CCF)*: provides the basic switching capabilities available in any switching system, including call and service processing and control.
- *Location Registration Functions (LRF_V and LRF_H)*: provide the service logic and service data function to manage the mobility aspects for wireless users. They are respectively associated to the VLR and HLR network entities.
- *Mobile Station Access Control Function (MACF)*: stores subscriber data and dynamically associates system resources with a particular set of call instance data.
- *Radio Access Control Function (RACF)*: provides the service logic and service data functionality specifically related to radio link.
- *Radio Control Function (RCF)*: provides the radio port and radio control.
- *Radio Terminal Function (RTF)*: interface that provides network call control functions to wireless users.
- *Service Control Function (SCF)*: commands call control functions in the processing of WIN provided and custom service requests.
- *Service Creation Entity Function (SCEF)*: provides the capability for the creation, verification, and testing on WIN services.
- *Service Data Function (SDF)*: contains customer and network data for real-time access by the SCF in the execution of WIN-provided services.

- *Service Management Access Function (SMAF)*: provides the human interface to service management functions.
- *Service Management Function (SMF)*: provides overall service management functionality for the network. The SMF may interact with any or all of the other FEs to perform service provisioning, monitoring, testing, and subscriber data management functions.
- *Service Switching Function (SSF)*: is associated with CCF and provides the set of functions and the recognition of triggers required for interaction between the CCF and SCF.
- *Specialized Resource Function (SRF)*: provides the specialized resources required for the execution of WIN-provided services (e.g., digit receivers, announcements, conference bridges, etc.).

The FEs related to wireless access mobility (ACF, LRF_V, LRF_H, MACF, RACF, RCF and RTF in Figure 6) were added in WIN, as they are not part of the original IN CS-2 [14].

3.3. Network Reference Model

The wireless Network Reference Model defines network entities (NEs) and the associated interface reference points that may logically comprise a wireless network. In essence, the NRM facilitates the specification of messages and protocols within WIN's stage 3 by allowing for the functional entities to be mapped to network entities in the physical plane. Figure 7 depicts a simplified version of WIN's NRM, as some of these entities have links to other entities of their type (e.g., MC, MSC, SCP, SME, and VLR). All these network entities are defined in ANSI-41.1 [6], except for IP, SCP, and SN, which have been added in WIN.

- *Authentication Center (AC)*: manages the authentication information related to the MS.
- *Base Station (BS)*: comprised of *Base Station Transceivers (BST)* and a *Base Station Controller (BSC)*, BS is the name for all the radio equipment located at each cell.
- *Equipment Identity Register (EIR)*: register to which user equipment identity may be assigned for record purposes.
- *Home Location Register (HLR)*: location register to which a user identity is assigned for record purposes such as subscriber information (e.g., profile information, current location, authorization period, etc.)
- *Intelligent Peripheral (IP)*: performs specialized resource functions such as playing announcements, collecting digits, performing speech-to-text or text-to-speech conversion, recording and storing voice messages, facsimile services, data services, and so forth.
- *Message Center (MC)*: entity that stores and forwards short messages.
- *Mobile Station (MS)*: interface equipment used to terminate the radio path at the user side. It provides the capabilities to access network services by the user.
- *Mobile Switching Center (MSC)*: automatic system that constitutes the interface for user traffic between the cellular network and other public switched networks, or other MSCs in the same or other cellular networks.
- *Service Control Point (SCP)*: acts as a real-time database and transaction processing system to provide service control and service data functionality.
- *Short Message Entities (SME)*: compose and decompose short messages.
- *Service Node (SN)*: provides service control, service data, specialized resources and call control functions to support bearer related services.
- *Visitor Location Register (VLR)*: retrieves information for handling of calls to or from a visiting subscriber.

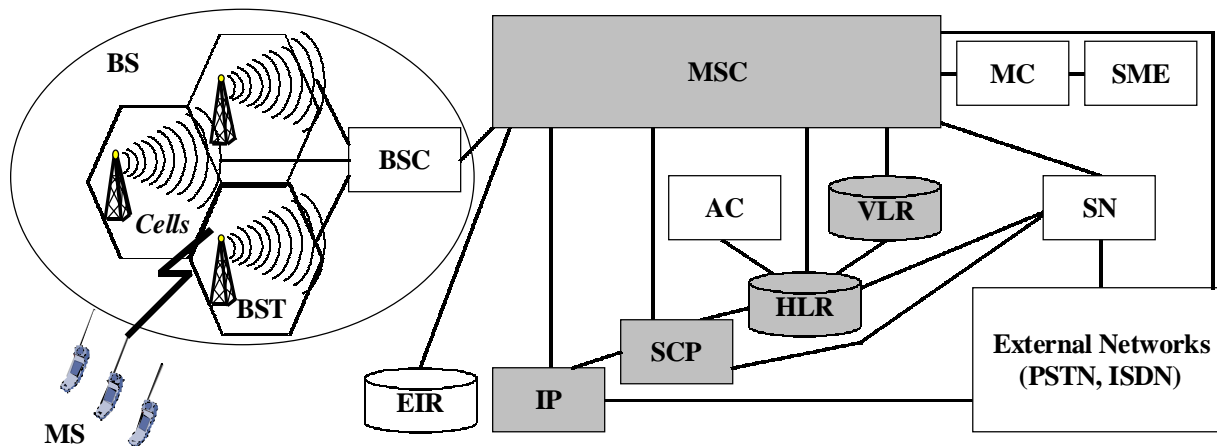

Figure 7 Wireless Network Reference Model
(adapted from Figure 2 of IS-41.1-WIN [18])

Real implementations of the NRM may vary with respect to how the network entities are distributed among various actual physical units. In cases where network entities are combined in the same physical equipment, the interface reference points become internal and need not adhere to interface standards. For instance, it is often the case that the VLR is part of the same piece of equipment as the MSC or as the HLR. This is a legacy problem caused by the original ANSI-41 NRM. The network entities are not really physical in the IN sense, but are rather a mix of functional and physical entities. This problem persists in much of the WIN specification, and especially in the numerous Message Sequence Charts based on NEs.

3.4. Mapping of DFM to NRM

Functional modeling in the DFM is a valuable tool for identifying the functions to be performed by network entities in the NRM without restricting possible implementations. However, implementations require ultimately that the FEs be allocated to specific NEs. The WIN standard contains, as an informative annex, an example of mapping between FEs and NEs (illustrated in Figure 8). This annex is not intended to restrict or prejudice in any way other possible allocations of FEs or interfaces. The standard does not enforce this mapping in order for the industry to preserve the freedom that is necessary for the evolution of future implementations. In this figure, the FEs and NEs involved in the ICS service are shaded in gray, and some minor NEs (EIR, MC and SME), which are often integrated to other NEs, have been omitted.

This mapping is similar to the one in Figure 4, and this combined structure enables the generation of stage 2 and stage 3 information flows when UCMs are bound to it. As an example, the next section will present the ICS UCM where the responsibilities are allocated to the relevant entities of this structure.

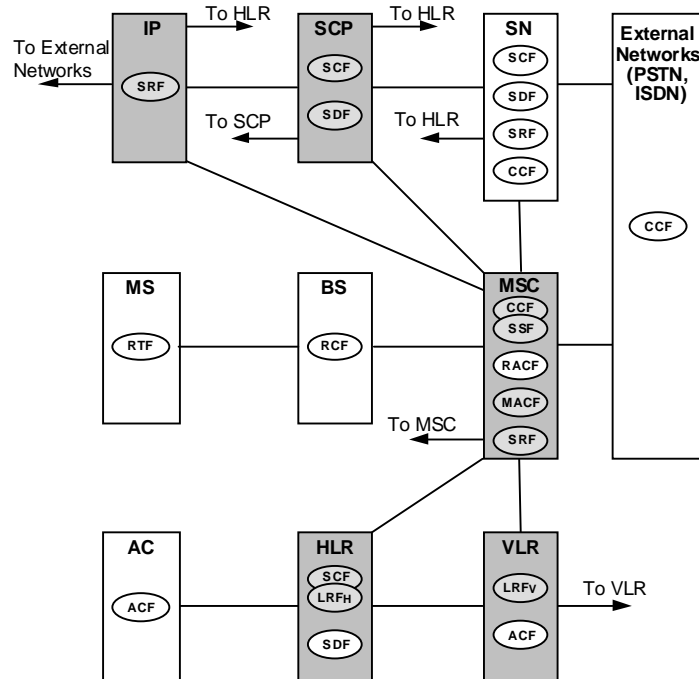

Figure 8 Possible Mapping of WIN Functional Entities to Network Entities
(adapted from Figure 40 of IS-41.7-WIN [18])

4. NEW METHODOLOGY WITH UCM

Over the years, several standardization committee members have started to complain about the use of the three-stage methodology. This approach is reaching its limits and is becoming cumbersome for many reasons, some of which being that users needs are difficult to define, that existing scenarios are often incomplete or obscure due to their length and complexity, and that protocol and procedure specifications are difficult to generate, interpret, and validate. Many of these problems are caused by the hiding of design decisions discussed in Section 2.

The WIN standard itself represents services with informal descriptions and tables in stage 1. In stage 2, message sequence charts illustrate the main service scenarios, but their components (the vertical lines) are network entities instead of functional entities. This goes against the theory behind IN and the three-stage methodology, and against the claim that the mapping of FEs to NEs provided in the informative annex (Figure 8) is included only for illustration purpose. Therefore, not only does the standard deviate from the methodology, but it also jumps from informal requirements directly to a level of details similar to that of Figure 5 (c) and, by doing so, is almost imposing a specific structure of NEs. Every decision taken along the way remains in the heads of those who edited the documents, and this situation obviously does not promote the *openness* of the standard.

In this context, Figure 9 depicts a new development approach that includes UCMs between the requirements and the description of information flows in terms of FEs. Its purpose is to achieve better and more complete descriptions, and to improve both the human understanding and the technical quality of the telecommunication standards.

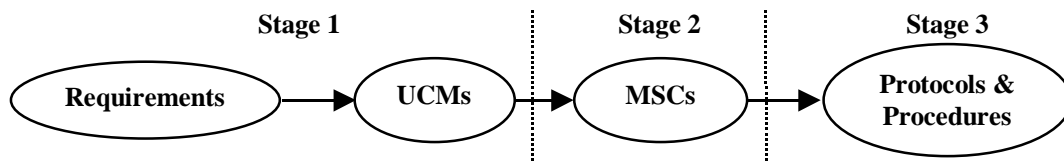

Figure 9 Proposed Standard Development Methodology

The approach of Figure 9 is one of *forward engineering*, where more details are taken into consideration at each new stage. Essentially, this methodology differs from that of Figure 1 in the following way:

- New stage 1 documents have, in addition to prose descriptions and tables, a representation of the services in terms of responsibilities and causal paths similar to the UCM of Figure 2.
- New stage 2 documents provide the mapping of UCM responsibilities to relevant FEs (like in Figure 3). Information flows are illustrated with MSCs in terms of FEs. These MSCs need to be correct according to their respective UCM bound to FEs. The refinement of responsibilities and of causality relationships is similar to Figure 5, but using the Distributed Functional Model (Figure 6) instead of the Network Reference Model (Figure 7). Traceability relationships are established during this refinement.
- New stage 3 documents include procedures and protocols based on FEs. They can also provide, for illustrative purpose, a mapping of FEs to NEs (Figure 4 and Figure 8). This enables the generation of NE-based MSCs (Figure 5), like the MSCs in today's stage 2, and of NE-based procedures and protocols.

With such a methodology, the documents would contain enough information for implementors to know how to adapt protocols and procedures for structures of FEs and NEs different from those of the published standard. By avoiding today's necessity to *reverse engineer* this information, products can be built faster and they have a better chance to interwork and to interoperate in a heterogeneous environment.

4.1. Reverse Engineering ICS

The current WIN standard [18] does not describe causal scenarios for its features, nor does it present the mapping of responsibilities to FEs or MSCs based on FEs. In order to provide a realistic example of forward engineering as suggested in Figure 9, the necessary information needs to be extracted from the current standard using a reverse engineering approach. Table 1 shows some of the steps necessary for the description of UCMs for ICS.

Step	Stage	From WIN	To UCMs
1	1	WIN informal description	Paths and responsibilities for the general WIN scenario
2	1	ICS informal description	Paths and responsibilities for the ICS scenario
3	2	DFM: Functional Entities	Components based on FEs
4	2	NRM: Network Entities and MSCs	Components based on NEs
5	2	Mapping of FEs to NEs	Mapping of responsibilities based on FEs and NEs

Table 1 From Current WIN Standard to UCMs

The first step is concerned with the description of a (partial) general scenario for the WIN standard. This UCM provides a context where specific services such as ICS can be inserted. In the second step, the focus is on the extraction of responsibilities and causal paths from the informal service, without any reference to components. The resulting UCMs become part of the new stage 1 documentation of the proposed methodology.

In the third step, UCM components are designed based on functional entities described in the Distributed Functional Model. This step is very difficult and error-prone, because there is not enough information about FEs responsibilities for specific services such as ICS. Hence, the UCMs responsibilities are designed according to the purpose of each functional entity. This UCM becomes part of the new stage 2 documentation.

The fourth and fifth steps consider UCM components based on networks entities, as used in current stage 2 information flows. The mapping of FEs to NEs is done according to the mapping example presented in the annex of the standard, and according to information flows based on NEs.

The next sub-sections presents several UCMs resulting from this exercise, as an example of what the proposed methodology could have brought to the forward engineering of the standard.

4.2. General WIN Scenario

The UCM in Figure 10 presents a general scenario for WIN that focuses on management of services and on call setup (with only ICS for the moment). The path at the bottom of the WirelessIntelligentNetwork system is triggered by StartRequest, an event related to registration, de-registration, authorization and de-authorization of services. It contains a UCM construct shaped in diamond that is called *stub*. A stub is an abstraction mechanism that can be refined by one or many sub-UCMs called *plugins*, which may themselves contain other stubs for a hierarchical definition of the path scenarios. The plugin for ReqServ will not be described in this paper (but the one for stub ICS will be in the next section). It is enough to mention that, for instance, the subscriber can request either to register or to de-register screening functions or screening factors for ICS through this plugin.

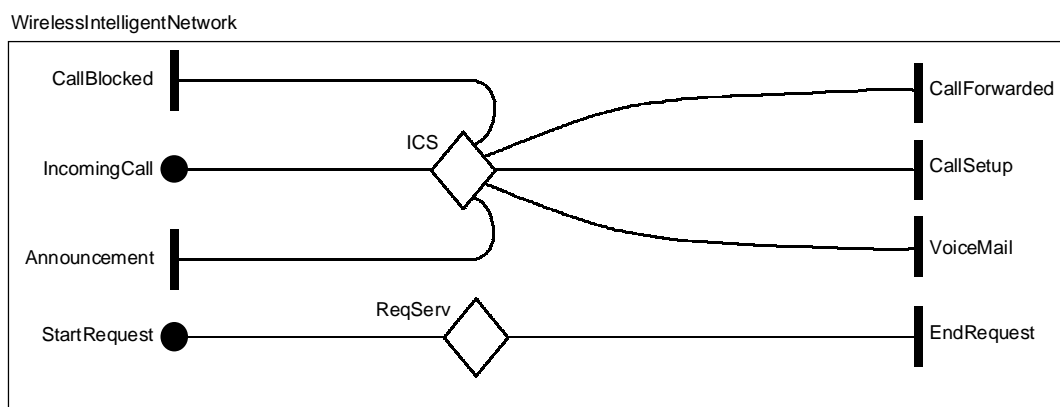

Figure 10 General WIN Scenario

The top path is more relevant to ICS. The start point (IncomingCall) leads to the ICS stub, which in turn results in one of the five possible situations that correspond to the different termination treatments introduced in Section 3.1: CallSetup, CallForwarded, VoiceMail, Announcement, and CallBlocked. Although this simple path can be extended with surrounding features, it is sufficient for providing the context in which a plugin for ICS can be developed.

4.3. UCM Plugin for ICS Service

A UCM plugin for ICS is illustrated in Figure 11. This UCM presents the UCM causality paths and the allocation of responsibilities to FEs to NEs. As explained at the beginning of

Section 4, only the paths and responsibilities would be described in stage 1, while stage 2 documents would include UCMs bound to FEs, and stage 3 would present UCMs bound to NEs. Due to space limitations, we combined them all in one single UCM, and we enumerated only the main responsibilities.

A plugin is bound to a stub in order to define the global causal flow of responsibilities. Start points in the plugin are bound to appropriate path segments going into the stub, whereas end points in the plugin are bound to appropriate path segments coming out of the stub.

Without getting into the details and subtleties of this UCM, its interpretation is essentially as follows. An incoming call tentative causes the request to be analyzed (Req by the CCF in the serving MSC). This causes the execution of a check function to determine whether the ICS service is active or not (Chk, by the LRF_H in the subscriber's HLR). If it is inactive, then the regular call setup scenario continues: the location of the called party is determined (Loc), the call is routed if the called party is visiting another location (stub Routing in MACF), and this results in the continuation of the call setup.

When ICS is active, the screening function is checked (SF, by the SDF in SCP) and performed (CF, by the SCF). This can result in the continuation of the call setup with or without a distinctive alerting (DA or NA), in a redirection to the voice mail (through VM, by the HLR's SCF), in the forwarding of the call to another subscriber (through Nb), in a specific announcement (through PBA in the intelligent peripheral's SRF), or in the call being blocked (through Blk). These five end points are the possible outcomes of ICS already discussed, and they are bound to their respective outgoing paths in the calling stub (Figure 10).

The plugin for the stub Routing (not shown here) contains paths that go through the LRF_V functional entity inside the VLR network entity, for the case where the called party is located in a place other than its home location.

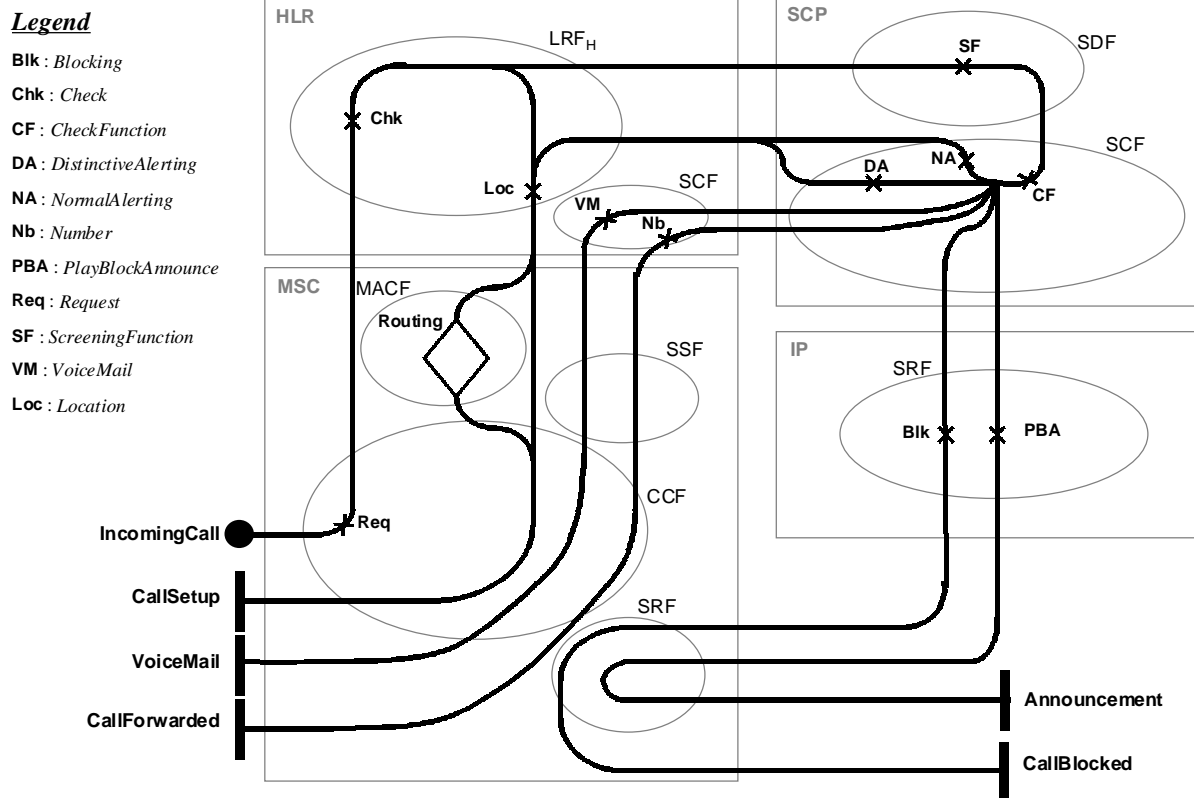

Figure 11 UCM Plugin for the ICS Stub

Use Case Maps represent scenarios in a compact form. A UCM of the complexity of that of ICS can lead to the generation of dozens of message sequence charts covering sequential scenarios based on FEs or on NEs. These MSCs can be generated according to Figure 11, provided that the links or channels between the different entities are included (and they are in Figure 6 and Figure 7).

4.4. ICS Interacting with Other Wireless Services

The general WIN scenario of Figure 10 can be extended in many ways to consider other wireless services and their interactions. For instance, the top path can be replaced by Figure 12, which includes conventional ANSI-41-D services such as emergency 911 (stub E911), Selective Call Acceptance (stub SCA) and Password Call Acceptance (stub PCA). The UCM in Figure 11 can be reused as a plugin for the new ICS stub.

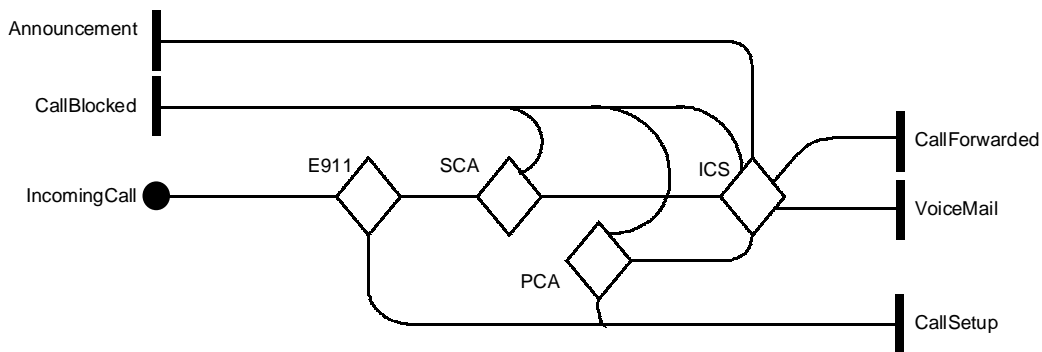

Figure 12 General WIN Scenario with ICS Interacting with Other Wireless Services

Undesirable interactions between features represent a complex problem that needs to be addressed early in the design process [4][8]. The WIN standard points out specific scenarios in stages 1 and 2 where feature interaction problems can happen. At the same time, it provides mechanisms to avoid them, such as precedence over services. For instance, the UCM indicates that E911 is given precedence over ICS, which has precedence over PCA. E911 is checked at the very beginning because emergency calls should never be screened or require a password.

5. CONCLUSION

There is an urgent need for better ways of describing complex telecommunication standards. The approach presented in this paper improves the current three-stage methodology by including, in its very first stage, causal scenarios represented as Use Case Maps. Services described as UCMs become useful thinking tools enabling discussions and evaluation of functional alternatives soon in the design process. When combined to a structure of functional entities, UCMs lead to the generation of information flows necessary for the documentation of stage 2. UCM scenarios can be reused when the underlying structure is modified. Finally, functional entities, and even UCMs, can be mapped to network entities in stage 3 (for illustration purpose). Procedures and protocols can then be defined according to these mappings. This methodology helps documenting design decisions currently buried under implementation details in many standards. It also improves the traceability between the stages, augments the consistency among the different viewpoints, and facilitates the validation and verification processes. Part of the methodology was illustrated with the Incoming Call Screening service of the new Wireless Intelligent Network standard.

It is worthy to note that although this example comes from the telecommunications area, the concepts presented here can be applied to distributed systems in general. Recently, UCMs have been used to describe agent systems [8] and a group communication server [2]. UCMs can also help generating formal prototypes. In particular, LOTOS [12] is appropriate for the formal specification and validation of systems initially described as UCMs. Instances of a UCM-LOTOS combined approach include a simple telephony system [1], a group communication server [2], interacting telephony features [4], and the Group-Call service of ETSI's General Packet Radio Service (GPRS) standard [5][10]. The feature interaction problem is specifically addressed with UCMs in [4] and [8].

UCMs raised a lot of interest recently. They are now supported by a drawing tool (the UCM Navigator [17]) and by a user group [19].

The new methodology is currently applied to several services of WIN Phase 2 (e.g., Pre-Paid Services and Location-Based Charging). These services focus on billing aspects of the system. The integration of formal description techniques at different stages, to support the formal prototyping and the validation of new services, is also being considered [3].

6. ACKNOWLEDGMENTS

This work is part of the project *Architecture and protocols for mobile telephone systems, with emphasis on the Wireless Intelligent Network*, funded by CITO and Nortel Networks. We would like to thank the UfoO's LOTOS Group for their support, and especially Luigi Logrippo and Jacques Sincennes for their judicious comments. We are indebted towards our industrial collaborators, John Visser and Jim Hodges, for their insights on WIN and standardization processes. Many thanks to Ray Buhr for his help on UCMs and to Andrew Miga for his numerous bug fixes and new functionalities added to the UCM Navigator. Finally, we acknowledge CAPES, NSERC, and FCAR for their financial support.

7. REFERENCES

- [1] Amyot, D., Bordeleau, F., Buhr, R.J.A., and Logrippo, L. (1995) "Formal support for design techniques: a Timethreads-LOTOS approach". In: *FORTE VIII, 8th International Conference on Formal Description Techniques*, Chapman & Hall, 57-72. <http://www.csi.uottawa.ca/~damyot/phd/forte95/forte95.pdf>
- [2] Amyot, D., Logrippo, L., and Buhr, R.J.A. (1997) "Spécification et conception de systèmes communicants: une approche rigoureuse basée sur des scénarios d'usage". In: *CFIP'97, Ingénierie des protocoles*, Liège, Belgium, September 1997. <http://www.csi.uottawa.ca/~damyot/cfip97/cfip97.pdf>
- [3] Amyot, D., Andrade, R., Logrippo, L., Sincennes, J., and Yi, Z. (1999) "Formal Methods for Mobility Standards". *IEEE 1999 Emerging Technology Symposium on Wireless Communications & Systems*, Dallas, USA, April 1999.
- [4] Amyot, D., Buhr, R.J.A., Gray, T., and Logrippo, L. (1999) "Use Case Maps for the Capture and Validation of Distributed Systems Requirements". To appear in: *ISRE'99, Fourth International Symposium on Requirements Engineering*, Limerick, Ireland, June 1999.
- [5] Amyot, D. and Logrippo, L. (1999) "Use Case Maps for the Prototyping and Validation of GPRS Group-Call". Submitted to: *Computer Communications, Special Issue on FDTs*.
- [6] ANSI/TIA/EIA (1997) *ANSI-41-D, Cellular Radiotelecommunications Intersystem Operations*.
- [7] Buhr, R.J.A. and Casselman, R.S. (1995) *Use Case Maps for Object-Oriented Systems*. Prentice-Hall, USA. http://www.UseCaseMaps.org/UseCaseMaps/pub/UCM_book95.pdf
- [8] Buhr, R.J.A., Amyot, D., Elammari, M., Quesnel, D., Gray, T., and Mankovski, S. (1998) "Feature-Interaction Visualization and Resolution in an Agent Environment". In: *FIW'98, Fifth International Workshop on Feature Interactions in Telecommunications Software Systems*, IOS Press, 135-149. <http://www.UseCaseMaps.org/UseCaseMaps/pub/fiw98.pdf>

- [9] Buhr, R.J.A. (1998) "Use Case Maps as Architectural Entities for Complex Systems". In: *IEEE Transactions on Software Engineering, Special Issue on Scenario Management*. Vol. 24, No. 12, December 1998. <http://www.UseCaseMaps.org/UseCaseMaps/pub/tse98final.pdf>
- [10] ETSI (1996), Digital Cellular Telecommunications System (Phase 2+), *General Packet Radio Service (GPRS); Service Description Stage 1 (GEM 02.60), Version 2.0.0*. November 1996.
- [11] Faynberg, I., Gabuzda, L.R., and Jacobson, T. (1997) "The Development of the Wireless Intelligent Network (WIN) and its Relation to the International Intelligent Network Standards". In: *Bell Labs Technical Journal*, Vol. 2, No. 3, summer 1997, 76-86.
- [12] ISO (1989) *LOTOS — A Formal Description Technique Based on the Temporal Ordering of Observational Behaviour*, Information Processing Systems, Open Systems Interconnection, IS 8807.
- [13] ISO/ITU-T (1995) – *Open Distributed Processing, Reference Model*, ISO 10746, ITU Recommendation X.901-904.
- [14] ITU-T (1995) *Q.1200 General Series, Intelligent Networks Recommendation Structure*. Geneva.
- [15] ITU-T (1996) *Recommendation Z. 120: Message Sequence Chart (MSC)*. Geneva.
- [16] Jacobson, I., Christerson, M., Jonsson, P., and Övergaard, G. (1993) *Object-Oriented Software Engineering, A Use Case Driven Approach*. Addison-Wesley, ACM Press.
- [17] Miga, A. (1998) *Application of Use Case Maps to System Design with Tool Support*. M.Eng. thesis, Dept. of Systems and Computer Engineering, Carleton University, Ottawa, Canada. <http://www.UseCaseMaps.org/UseCaseMaps/tools/ucmnav/>
- [18] TIA/EIA (1998) *Wireless Intelligent Networks (WIN)*. Additions and modifications to ANSI-41 (Phase 1). TR-45.2.2.4, PN-3661 Ballot Version, May 1998.
- [19] *Use Case Maps Web Page* (1999). <http://www.UseCaseMaps.org>

8. ABBREVIATIONS AND ACRONYMS

AC	Authentication Center (NE)	MS	Mobile Station (NE)
ACF	Authentication Control Function (FE)	MSC	Message Sequence Chart (interaction diagram)
ANSI	American National Standard Institute	MSC	Mobile Switching Center (NE)
BS	Base Station (NE)	NE	Network Entity
BSC	Base Station Controller (NE)	NRM	Network Reference Model
BST	Base Station Transceiver (NE)	PCA	Password Call Acceptance
CCF	Call Control Function (FE)	PSTN	Public Switched Telephone Network (NE)
CS-2	IN Capability Set 2	RACF	Radio Access Control Function (FE)
DFM	Distributed Functional Model	RCF	Radio Control Function (FE)
E911	Emergency 911	RTF	Radio Terminal Function (FE)
EIA	Electronic Industries Association	SCA	Selective Call Acceptance
EIR	Equipment Identity Register (NE)	SCEF	Service Creation Environment Function (FE)
ETSI	European Telecom. Standard Institute	SCF	Service Control Function (FE)
FE	Functional Entity	SCP	Service Control Point (NE)
HLR	Home Location Register (NE)	SMAF	Service Management Access Function (FE)
ICS	Incoming Call Screening	SME	Short Message Entity (NE)
IN	Intelligent Network	SMF	Service Management Function (FE)
IP	Intelligent Peripheral (NE)	SN	Service Node (NE)
IS	Interim Standard	SSF	Service Switching Function (FE)
ISDN	Integrated Services Digital Network (NE)	SRF	Specialized Resource Function (FE)
ITU	International Telecommunication Union	TIA	Telecommunications Industry Association
LRFH	Location Registration Function - HLR (FE)	UCM	Use Case Map
LRFV	Location Registration Function - VLR (FE)	UML	Unified Modelling Language
MACF	Mobile Station Access Control Function (FE)	VLR	Visitors Location Register (NE)
MC	Message Center (NE)	WIN	Wireless Intelligent Network